



ORIGINAL INSTRUCTIONS

TABLE OF CONTENTS

Welcome to Lumberjack!

Dear Customer, Congratulations on your purchase. Before using the product for the first time please be sure to read these instructions for use. They provide you with all information necessary for using the product safely and to ensure its long service life.

Closely observe all safety information in these instructions!

General Power Tool Safety Warnings.....	01
Symbols & Cable Rating Chart	02
Machine Details and Product Features... ..	03
Assembly... ..	04
Operation... ..	05
Maintenance and Service & Lumberjack Guarantee.....	07
Parts List & Parts Diagram... ..	09

GENERAL POWER TOOL SAFETY WARNINGS

Read all safety warnings and all instructions –

Failure to follow the warnings and instructions may result in electric shock, fire and/or serious injury.

1. Work Area Safety

1.1 Keep work area clean and well lit. Cluttered or dark areas invite accidents.

1.2 Keep children and bystanders away while operating this tool. Distractions can cause you to lose control.

2. Personal Safety

2.1 Stay alert, watch what you are doing and use common sense when operating this tool.

Do not use this tool while you are tired or under the influence of drugs, alcohol or medication. A moment of inattention whilst operating this tool may result in serious personal injury.

2.2 Use personal protective equipment (PPE).

Always wear eye protection. Protective equipment such as dust masks, non-skid shoes, hard hats, or hearing protection used for appropriate conditions will reduce the risk of personal injuries.

2.3 Do not overreach. Keep proper footing and balance at all times. This enables better control of any other tool used with this tool in unexpected situations.

2.4 Dress properly. Do not wear loose clothing or jewellery. Keep your hair, clothing and gloves away from moving parts. Loose clothes, jewellery or long hair can be caught in moving parts.

2.5 If devices are provided for the connection of dust extraction and collection facilities, ensure these are connected and properly used. Use of dust collection can reduce dust-related hazards.

3. Service

3.1 Have your tools serviced by a qualified repair person using only identical replacement parts.

This will ensure that the safety of the power tool is maintained.

4. Additional Safety and Working Instructions

4.1 Dusts from materials such as lead-containing coatings, some wood types, minerals and metals can be harmful to one's health and cause allergic reactions, leading to respiratory infections and/or cancer. Materials containing asbestos may only be worked by specialists. Observe the relevant regulations in your country for the materials to be worked.

4.2 Prevent dust accumulation at the workplace.

Dusts can easily ignite.

SYMBOLS AND POWER RATING CHART



Danger! – Read the operating instructions to reduce the risk of injury.



Caution! Wear safety goggles.



Caution! Wear ear defenders. The impact of noise can cause damage to hearing.



Caution! Risk of Injury! Do not reach into the running saw blade.



Caution! Wear a dust mask.

MACHINE DETAILS AND PRODUCT FEATURES

Machine Details

Specifications:

Min Thickness of Work piece - 8mm

Max Thickness of work piece - 32mm

Max Width of Work Piece:

DTJ300 - 300mm

DTJ600 - 600mm

Max Offset Capacity - 25mm

Package Contents:

Dovetail Jig

Intended Use

This jig is intended to cut both male and female dovetail joints into wood and wood like materials.

Product Features

1. Locking Clamp Handle
2. Eccentric Cam
3. Eccentric Bar
4. Clamp
5. Clamp adjusting Screw
6. Template Securing Screw
7. Backstop Locking Screw
8. Horizontal Stop
9. Vertical Stop
10. Back Stop
11. Template

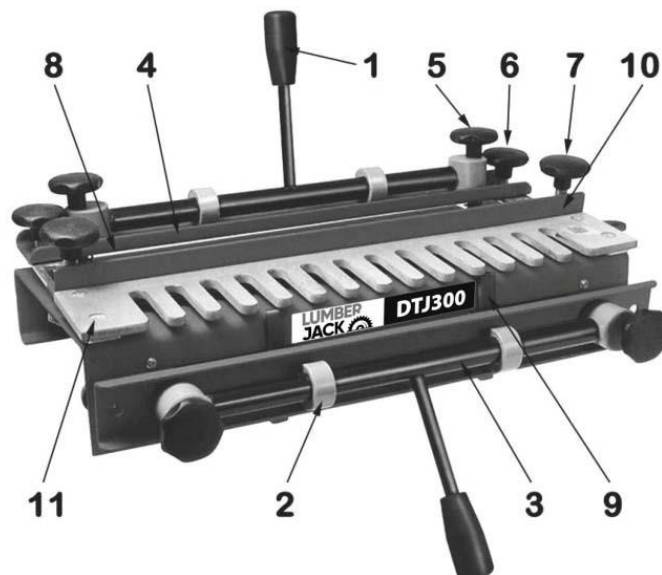

ASSEMBLY INSTRUCTIONS

Assembly

Carefully remove all parts included in the delivery from their packaging.

Remove all packaging material from the machine and the accessories provided.

Before starting the operation of the machine for the first time, check if all parts listed in the box content section have been supplied

Note: Check the power tool for possible damage. Before further use of the machine, check that all protective devices are fully functional. Any lightly damaged parts must be carefully checked to ensure flawless operation of the tool. All parts must be properly mounted and all conditions fulfilled that ensure faultless operation.

Damaged protective devices and parts must be immediately replaced by an authorised service centre.

Assembling the Jig

Screw the front and top handles into the eccentric bars.

– The workpieces will be locked when the top locking clamp handle is pushed away from you and when the lower locking clamp handle is pushed downwards.

Mounting the Jig

There are four holes provided in the base for mounting the jig.

– Mount the jig to a bench as shown and secure using suitable crews (not supplied).

– The jig must be mounted flush with the front edge of the workbench.

– Make sure there is enough space behind the jig to accommodate the longest length of timber you are likely to work on.

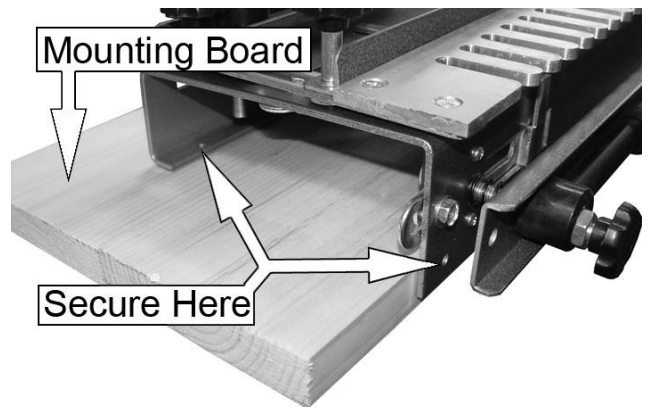

OPERATION

Operation

Setting the End Stops

– Use a set square to draw a pencil line halfway across the first finger of the template. The line must be square to the edges of the template.

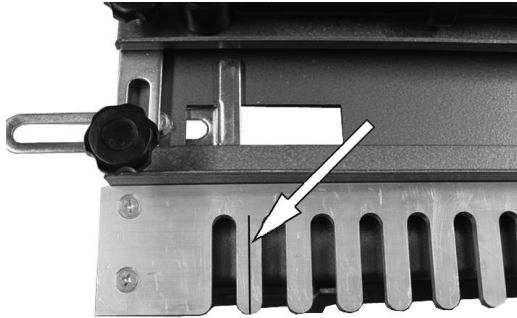

– Line up the inside edge of the left horizontal stop with the line you just drew on the template. Use a set square to ensure the stop is square to the jig.

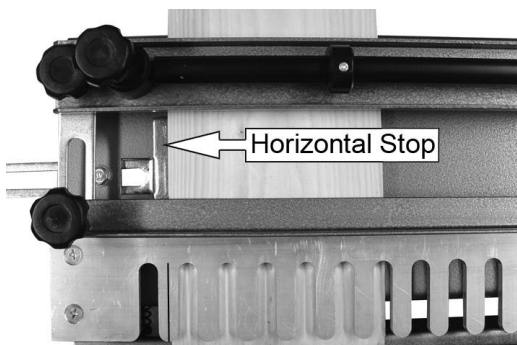

– Offset the vertical stop 1/2" to the right of the horizontal stop. Ensure the vertical stop is square to the top of the jig.

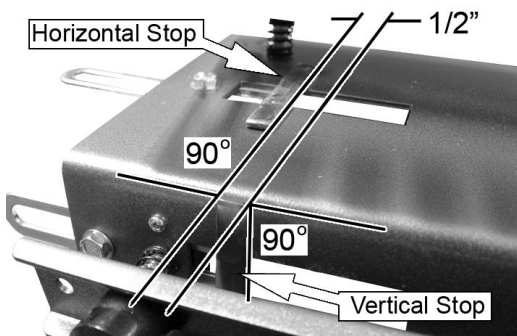

– Mirror these settings on the righthand side of the jig.

Placing Work Pieces

– Align the timber so that the side of the work piece is mounted in the front vertical clamp. It should extend above the front edge of the jig by the thickness of the piece to be mounted under the top clamp (front or back of the drawer).

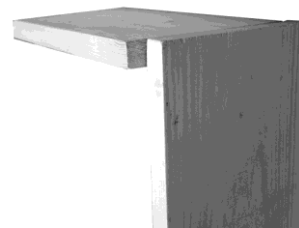
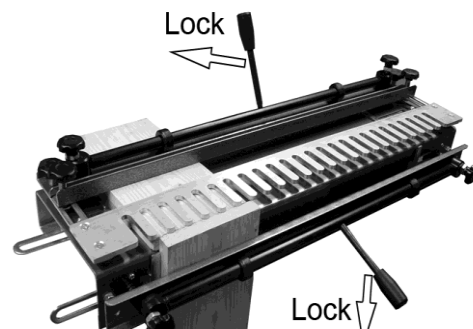

– The piece of timber in the top clamp is then butted up to this, so that both pieces are flush under the template.

– The two pieces sit in the jig as shown on the right. Make sure that both pieces are butted up against the horizontal / vertical stops.

– Use the locking clamp handles to secure the wood to the jig. You may need to adjust the top and front clamp bars to suit the thickness of the timber using the clamp adjusting screws at either end of each clamp bar so that the wood is held firmly in place. When narrow pieces of wood are being used, place another piece of wood (exactly

OPERATION

the same thickness) underneath the clamp bar at the opposite end to ensure an even grip on the wood and to avoid distorting the bars.

Setting the Template Position

– Unlock the two template securing screws and position the template so that the tips of the fingers sit 3mm back from the edge of the vertically mounted timber.

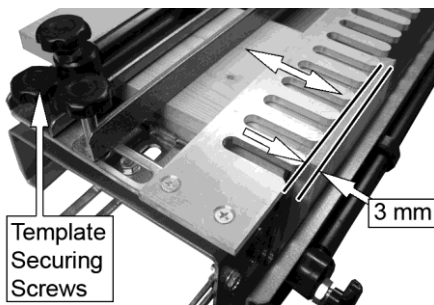

– Lock the template into position using the two template securing screws.

Setting the Backstop

The distance the backstop needs to be positioned from the front of the template fingers depends on the size of router base fitted to your router,

The formula to calculate this is:-

$$\left(\frac{\text{diameter of router base}}{2} \right) + 2 \times \text{thickness of work piece} - \left(\frac{\text{cutter diameter}}{2} \right)$$

– Set a micrometer or Vernier caliper to the calculated depth and adjust the backstop as shown (next page).

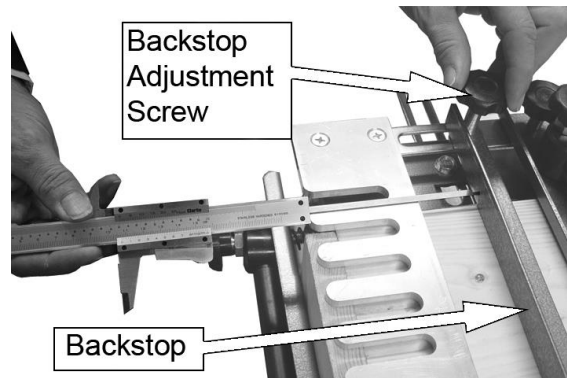

– Lock into place using the backstop locking screws. It is not essential that this setting is exact at this stage as final adjustments can be made later on.

– Ensure that the template and back stop stay parallel with the front edge of the jig during this setting procedure.

Setting the Cutter Depth

– Fit the bearing guided router bit securely into the router collet.

– Adjust the cutter depth, until the bottom of the router bit protrudes 10-11 mm below the template fingers.

– You may need to fit a packing piece between the template and the timber to ensure good contact between the bearing and the slots in the template.

– The cutting depth is critical to the final fit of the joint, with as little as 0.5mm change in depth making all the difference.

MAINTENANCE, SERVICE & LUMBERJACK GUARANTEE

Maintenance and Service

– **Before each use** inspect the general condition of the machine. Check for loose screws, misalignment or binding of moving parts, cracked or broken parts, and any other condition that may affect its safe operation.

– **Each day** remove all sawdust and debris from the jig with a soft brush, cloth or vacuum. Do not use solvents or caustic agents to clean the jig.

1. Guarantee

1.1 Lumberjack guarantees that for a period of 12 months from the date of purchase the components of qualifying products (see clauses 1.2.1 to 1.2.8) will be free from defects caused by faulty construction or manufacture.

1.2. During this period Lumberjack, will repair or replace free of charge any parts which are proved to be faulty in accordance with paragraph 1.1 providing that:

1.2.1 You follow the claims procedure set out in clause 2

1.2.2 Lumberjack and its authorised dealers are given reasonable opportunity after receiving notice of the claim to examine the product

1.2.3 If asked to do so by Lumberjack or its Authorised dealer, you return the product at your own cost to Lumberjack's or supplying Authorised Dealer's premises, for the examination to take place clearly stating the Returns Material Authorisation number given by Lumberjack or an Authorised Dealer.

1.2.4 The fault in question is not caused by industrial use, accidental damage, fair wear and tear, wilful damage, neglect, incorrect electrical connection, misuse, or alteration or repair of the product without approval.

1.2.5 The product has been used in a domestic environment only.

1.2.6 The fault does not relate to consumable items such as blades, bearings, drive belts, or other wearing parts which can reasonably be expected to wear at different rates depending on usage.

LUMBERJACK GUARANTEE

1.2.7 The product has not been used for hire purposes.

1.2.8 The product has been purchased by you as the guarantee is not transferable from a private sale.

2. Claims Procedure

2.1 In the first instance please contact the Authorised Dealer who supplied the product to you. In our experience many initial problems with machines that are thought to be faulty due to faulty parts are actually solved by correct setting up or adjustment of the machine. A good Authorised Dealer should be able to resolve the majority of these issues much more quickly than processing a claim under the guarantee. If a return is requested by the Authorised Dealer or Lumberjack, you will be provided with a Returns Material Authorisation number which must be clearly stated on the returned package, and any accompanying correspondence. Failure to provide a Returns Material Authorisation number may result in item being refused delivery at Authorised Dealer.

2.2 Any issues with the product resulting in a potential claim under the guarantee must be reported to the Authorised Dealer from which it was purchased within 48 hours of Receipt.

2.3 If the Authorised Dealer who supplied the product to you has been unable to satisfy your query, any claims made under this Guarantee should be made directly to Lumberjack. The Claim itself should be made in a letter setting out the date and place of purchase, giving a brief explanation of the problem which has led to the claim. This letter should be then sent with proof

of purchase to Lumberjack. If you include a contact number with this it will speed your claim up.

2.4 Please note that it is essential that the letter of claim reaches Lumberjack on the last day of this Guarantee at the latest. Late claims will not be considered.

3. Limitation of Liability

3.1 We only supply products for domestic and private use. You agree not to use the product for any commercial, business or resale purposes and we have no liability to you for any loss of profit, loss of business, business interruption or loss of business opportunity.

3.2 This Guarantee does not confer any rights other than these expressly set out above and does not cover any claims for consequential loss or damage. This Guarantee is offered as an extra benefit and does not affect your statutory rights as a consumer.

4. Notice

This Guarantee applies to all product purchased from an Authorised Dealer of Lumberjack within the United Kingdom. Terms of Guarantee may vary in other countries.

Parts List & Parts Diagram

No.	Description	No.	Description
1	Working table	13	Eccentric rod
2	Washer	14	Screw
3	Bolt	15	Spring
4	Nut	16	Bracket frame
5	Side brace	17	Screw
6	Fixing screw "A"	18	Comb table
7	Fixing screw "B"	19	Stop pin
8	Spacing screw	20	Adjusting nut
9	Bar fixing stand	21	Support
10	Eccentric wheel	22	Screw
11	Rotary rod	23	Rod fixer
12	Knob		

